

Name:

Class:



20 Listen and draw lines. There is one example.

Paul

John

Vicky

Daisy

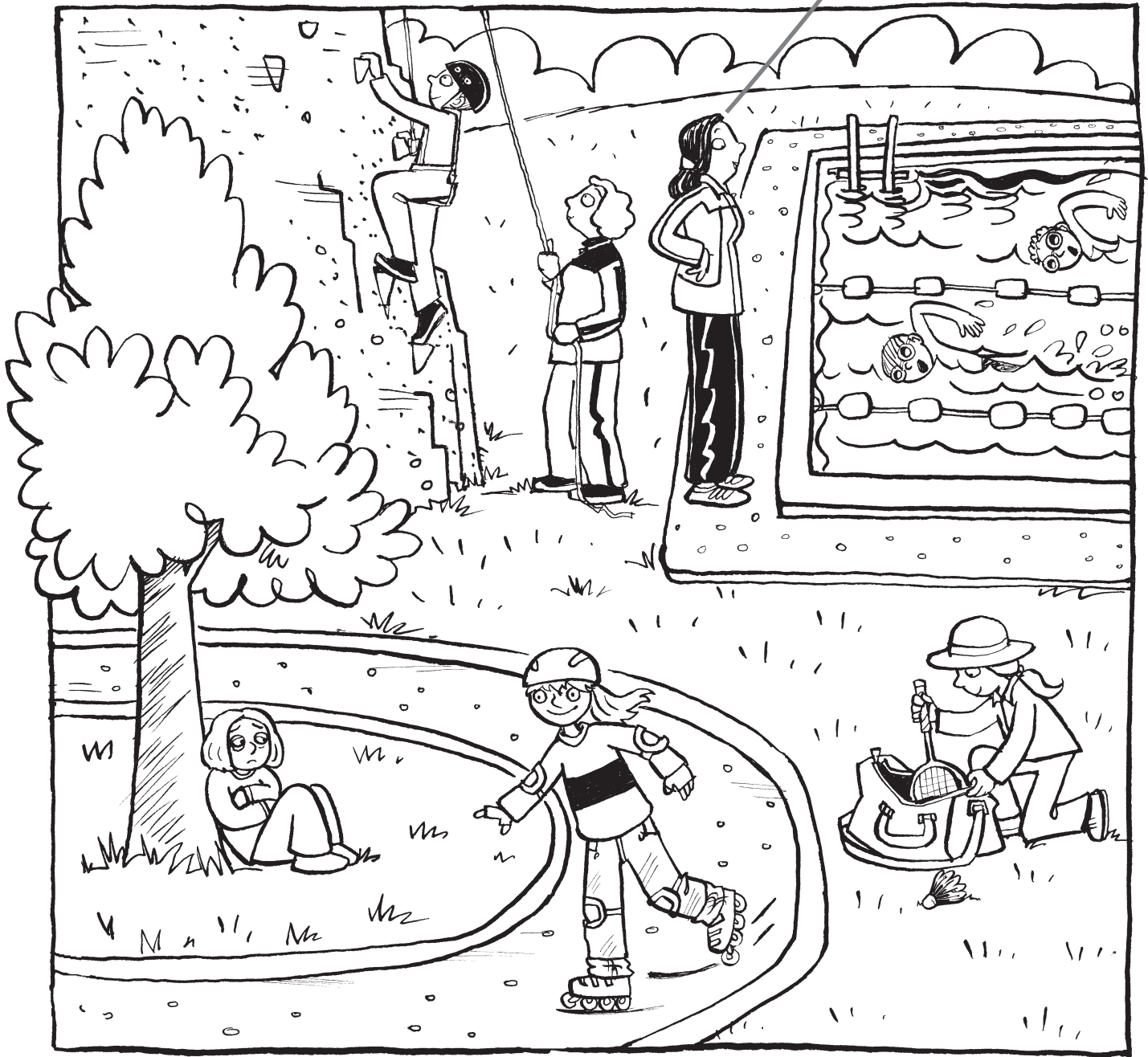

Jane

Jim

Mary

2

21 Listen and write. There is one example.

THE LIBRARY

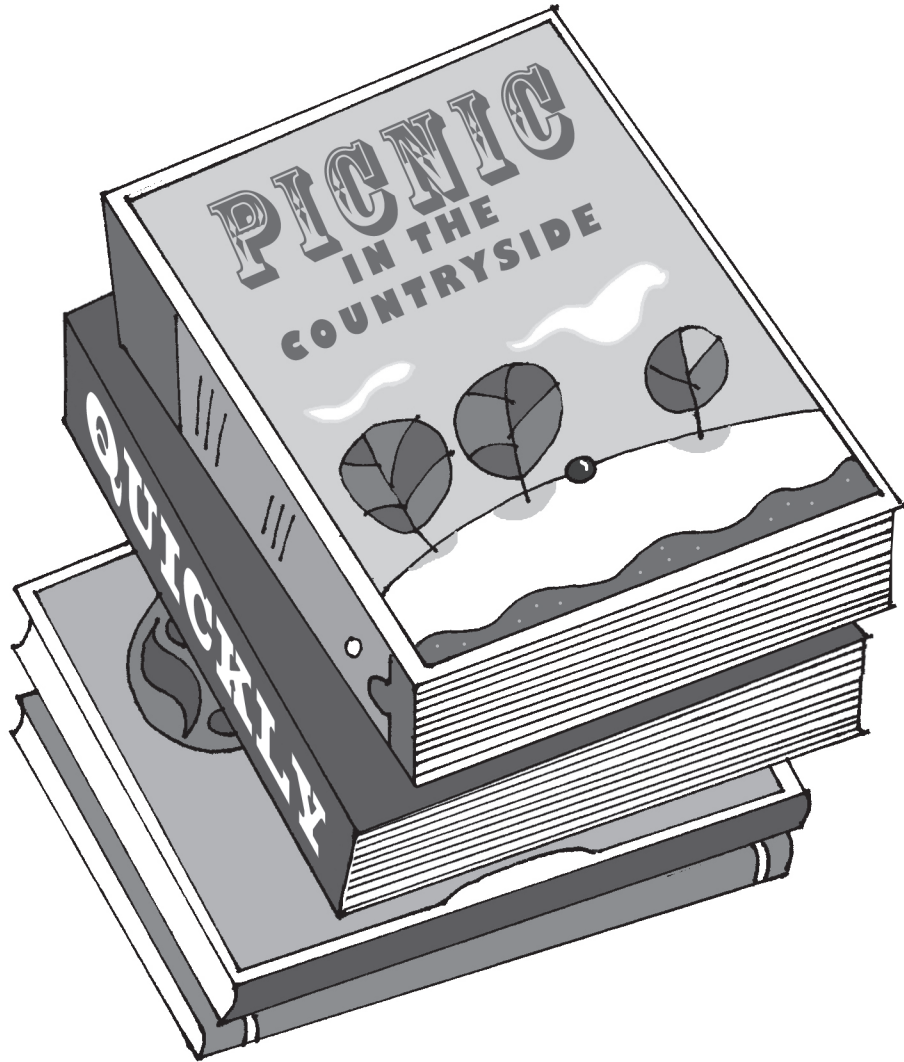

- 1
- 2
- 3
- 4
- 5

Name: SallyBrown.....
How old?
School: School
Teacher's name: Mrs
Favourite author: Wilson
Favourite book:

3

22 What did Paul do last week?

Listen and draw a line from the day to the correct picture. There is one example.



Monday

Tuesday



Wednesday

Thursday

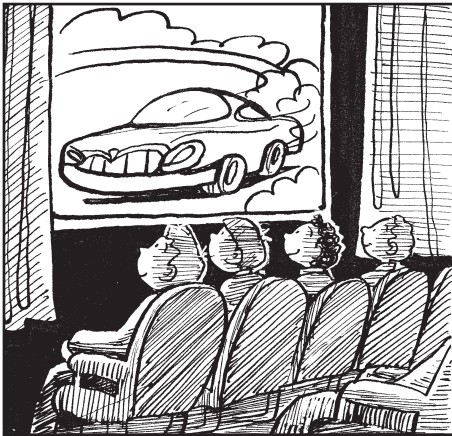

Friday



Saturday

Sunday



4

23 Listen and tick (✓) the box. There is one example.

What was the matter with Jim?



A



B



C

1 Which is the doctor?



A



B



C

2 Where did Jim go on Friday?



A



B



C

3 What does Jim like best?



A



B



C

4 How old is Jim's sister?



A



B



C

5 How many books did she have for her birthday?



A



B



C

5

24

Listen and colour and write. There is one example.

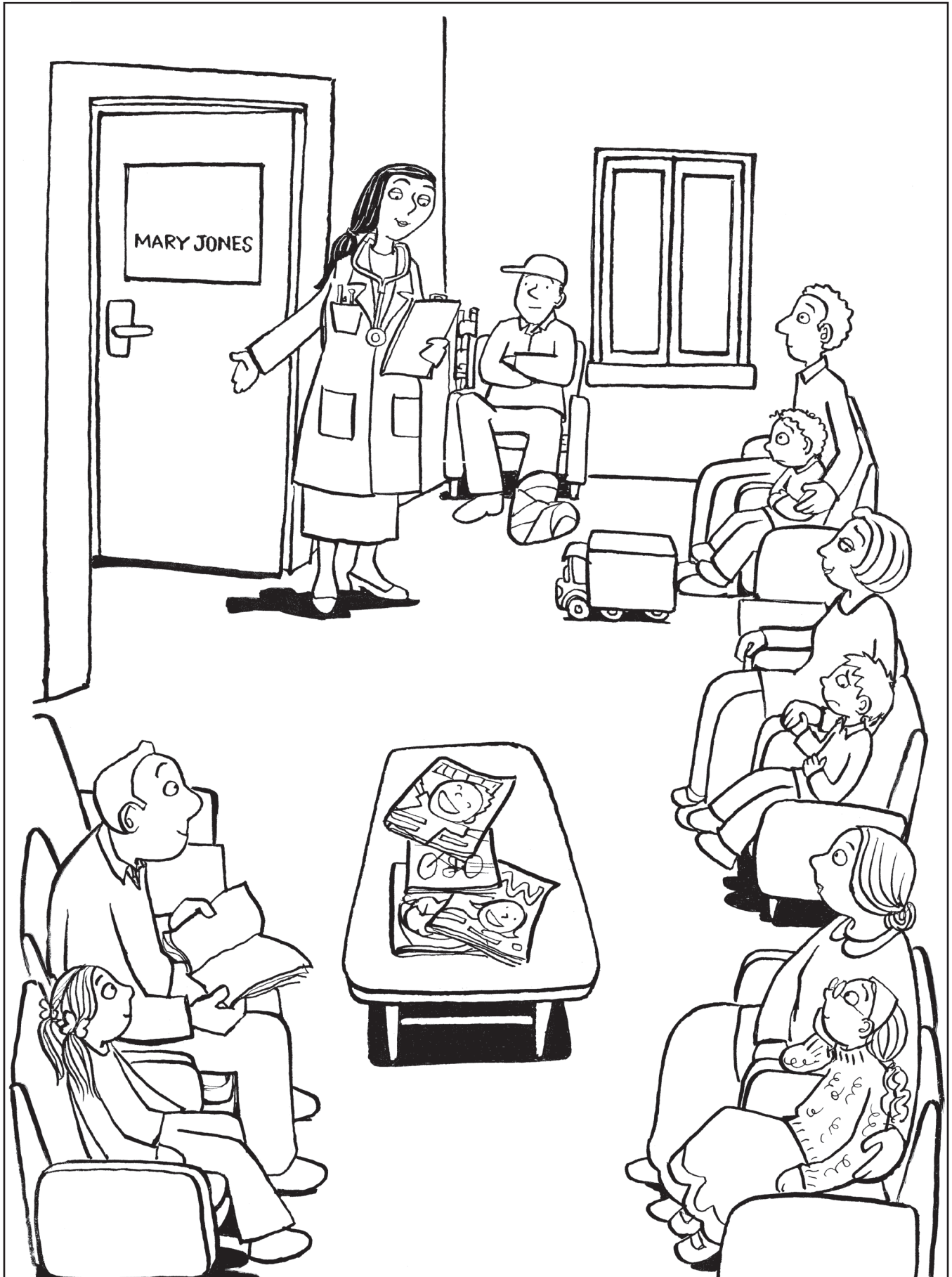

Name:

Class:

1 Look and read. Choose the correct words and write them on the lines. There is one example.



a doctor

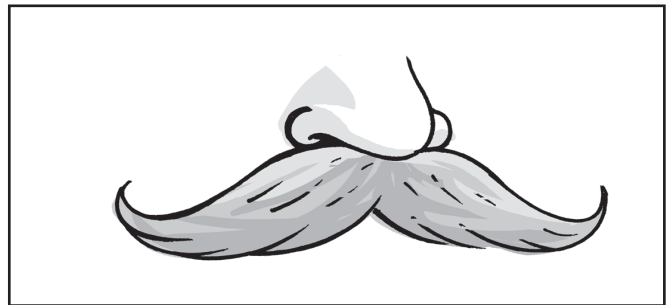

a moustache

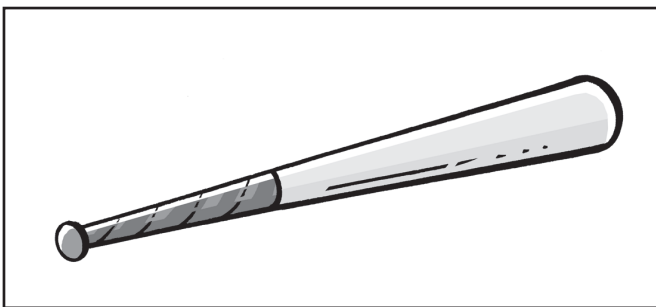

a bat

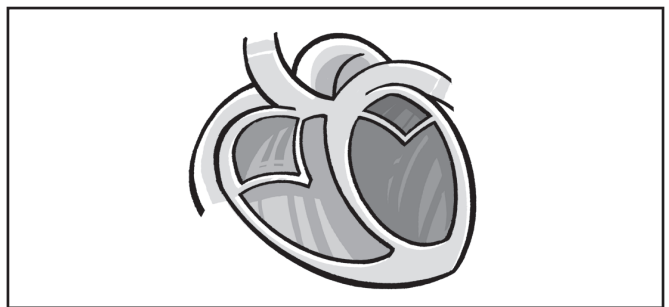

the heart

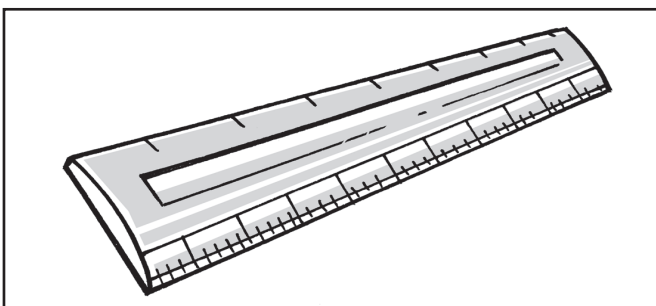

a ruler

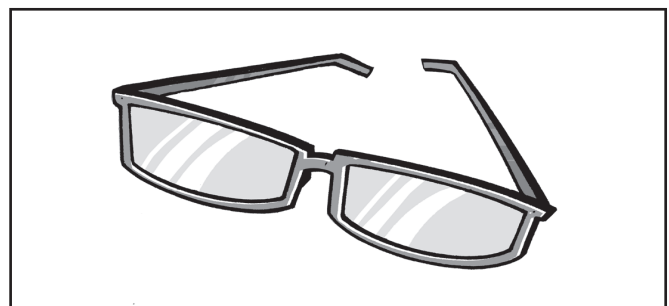

glasses



a beard

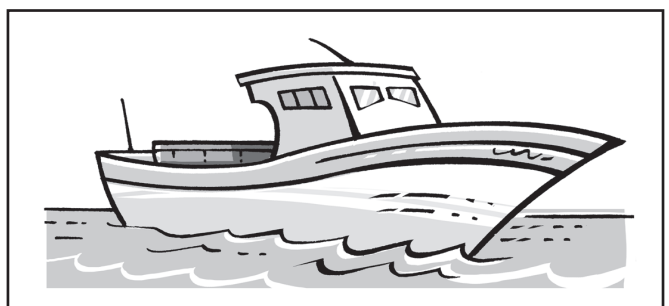

a boat

Example

This moves blood around our body.

.....the heart.....

Questions

① People who can't see very well wear these.

.....

② Some men have this on their face between their nose and their mouth.

.....

③ You use this to measure length.

.....

④ You sail in this.

.....

⑤ You use this to hit the ball in baseball.

.....

⑥ This person helps you when you are ill.

.....

2 Look and read. Write **yes** or **no**.

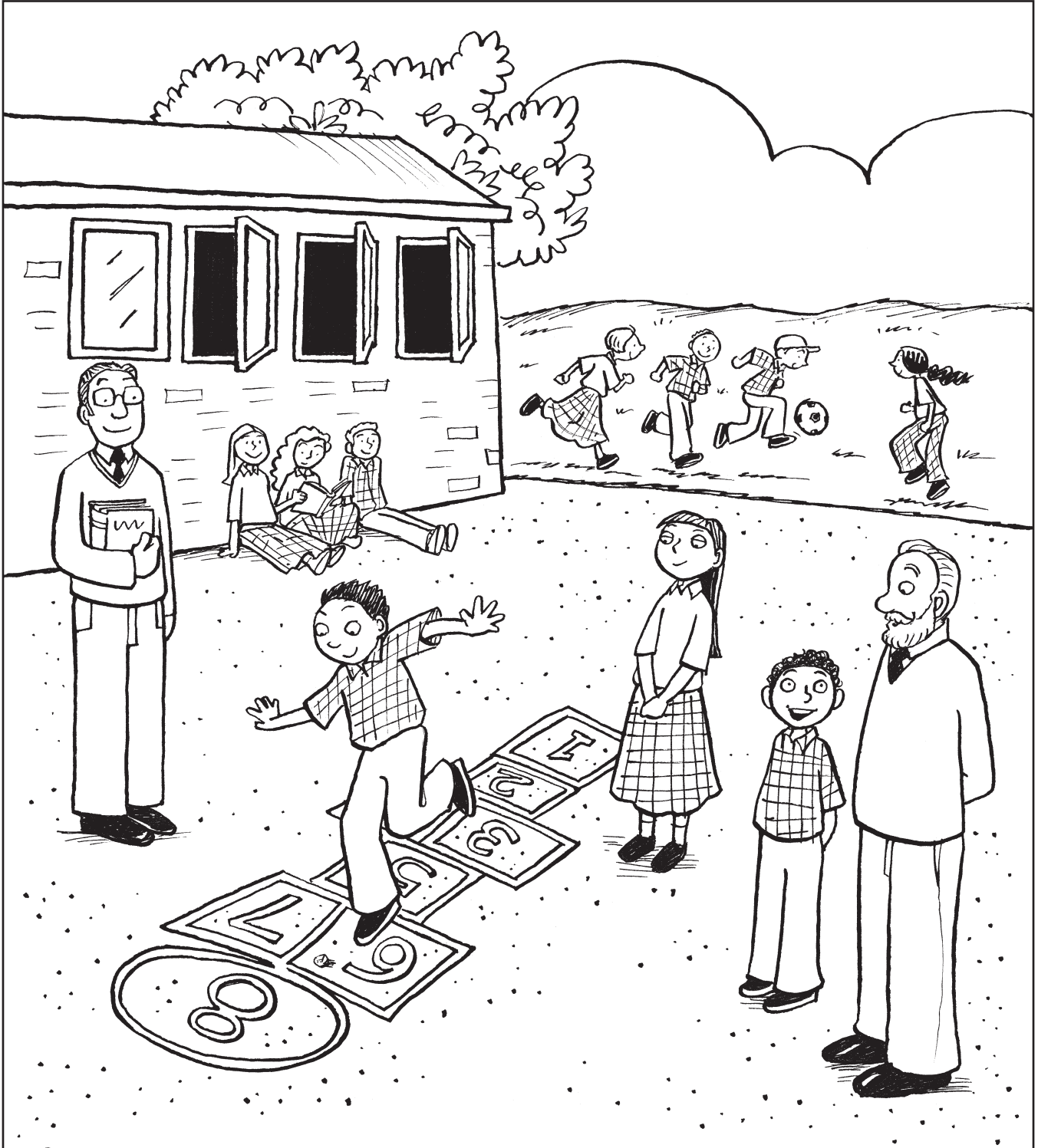

Examples

The teacher with a beard is talking to a boy.

..... yes

Four windows are open.

..... no

Questions

- 1 A girl is hopping carefully.

- 2 The boy with a cap is playing football.

- 3 There is a tree behind the school.

- 4 The teacher with glasses is carrying a bag.

- 5 The girl with short hair is wearing a skirt.

- 6 A girl and a boy are reading.

3**Read the text and choose the best answer.****Sally is talking to her friend Mary.****Example**

Sally: Hello, Mary. How are you?

Mary: A I'm your friend.

B I'm fine, thanks.

C I'm slow.

Questions

1 Sally: What are you doing?

Mary: A I'm going to my dance class.

B I go to my dance class.

C I went to my dance class.

- 2** Sally: Where is the dance class?
Mary: A I like dancing.
B At school.
C At six o'clock.
- 3** Sally: Do you go every Thursday?
Mary: A Yes, and Tuesdays, too.
B I went on Thursday.
C I'm going on Thursday.
- 4** Sally: Do you like dancing?
Mary: A Yes, I like.
B Yes, please.
C Yes, I do.
- 5** Sally: Why do you like dancing?
Mary: A It's terrible.
B It's exciting.
C When I was little.
- 6** Sally: You must go now. See you!
Mary: A Yes, I can see you.
B Where are you?
C Goodbye.



4 Read the story. Choose a word from the box.
Write the correct word next to numbers 1–6.
There is one example.

My name is Paul. I am a teacher at a sports centre. I teach badminton,

① _____, baseball and running. Yesterday, a new

② _____ came to the class for the first time. When we

played baseball, she hit the ③ _____ very hard and she

④ _____ very quickly. We couldn't find the ball and her team

won the game. Her team was very ⑤ _____. The next

⑥ _____ we played, I took lots of balls so we could play

all the time.



sad

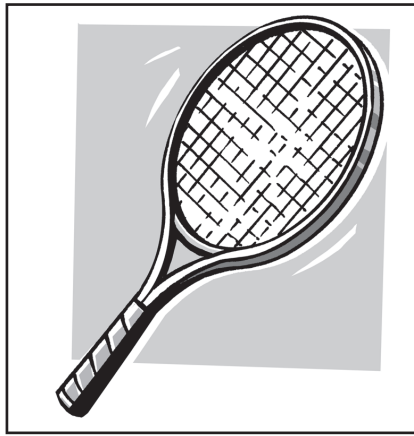

tennis



ran

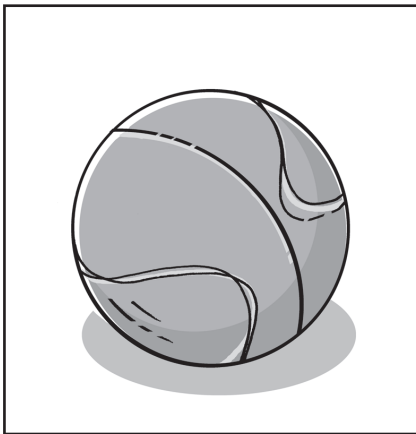

ball

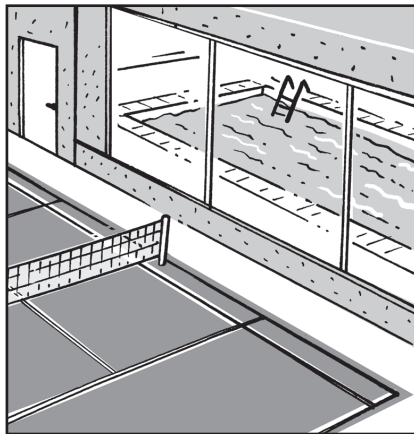

sports centre



day



girl



happy



boy

7 Now choose the best name for the story. Tick one box.

The baseball game

The tennis class

A game that Paul couldn't play

- 5** Look at the pictures and read the story. Write some words to complete the sentences about the story. You can use 1, 2 or 3 words.

Sam, the teacher!



Sam lives in the countryside with his parents and his sister, Mary, and his brother, Paul. Sam is ten, Mary is eight and Paul is six. They live in the countryside but they go to school in the city. Sam is the one who likes Science, his sister is the one who likes Sport and his brother is the one who likes Art.

Examples

Sam's familylive in the..... countryside.

Sam has asister..... called Mary.

Questions

- 1** The children go to school
- 2** Sam's favourite subject is
- 3** is the one who likes Sport.



Last week, Sam had a class about the human body. He listened carefully and when he went home he gave his younger brother and sister a class about the subject. They wanted to listen because it was very interesting. Sam said, 'We move because we have 600 muscles in our body. The muscles need oxygen. We use our lungs to take oxygen from the air into our body.'

- 4 Last week, Sam studied at school.
- 5 Sam gave his brother and sister a class when he went
.....
- 6 Mary and Paul wanted to learn because it was very
.....
- 7 We use our lungs because our muscles



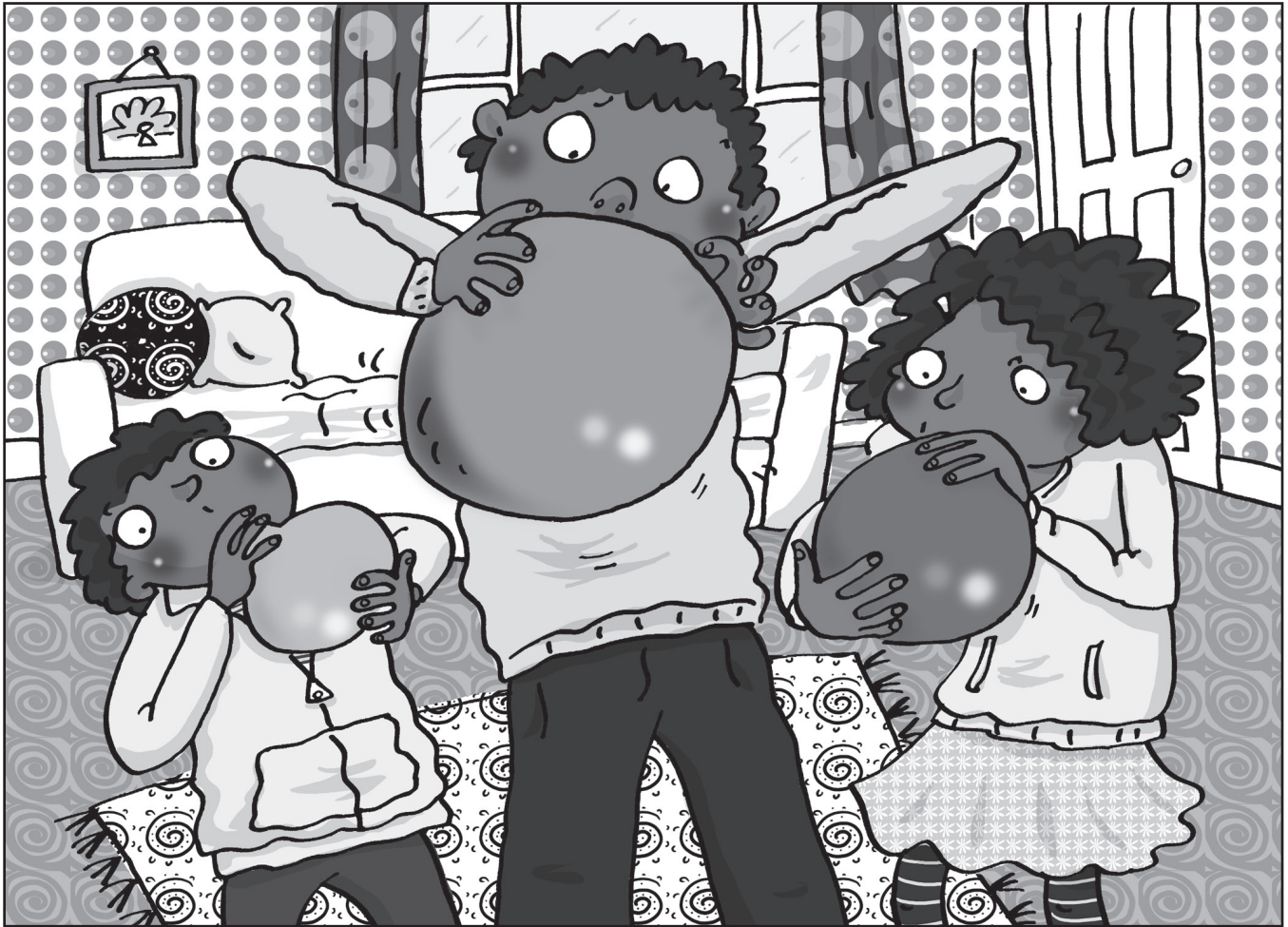

Sam showed his brother and sister how to test their lungs. They took a balloon. First, Sam breathed into the balloon and measured it with the air in. Mary was second and Paul was third. Sam's balloon was bigger than Mary's and Mary's was bigger than Paul's. Now Mary and Paul think that Science is exciting, too.

- 8 The children used to test their lungs.
- 9 First the children breathed into the balloons and then they them.
- 10 Sam's brother and sister think that is exciting.

Blank page



6

Read the text. Choose the right words and write them on the lines.

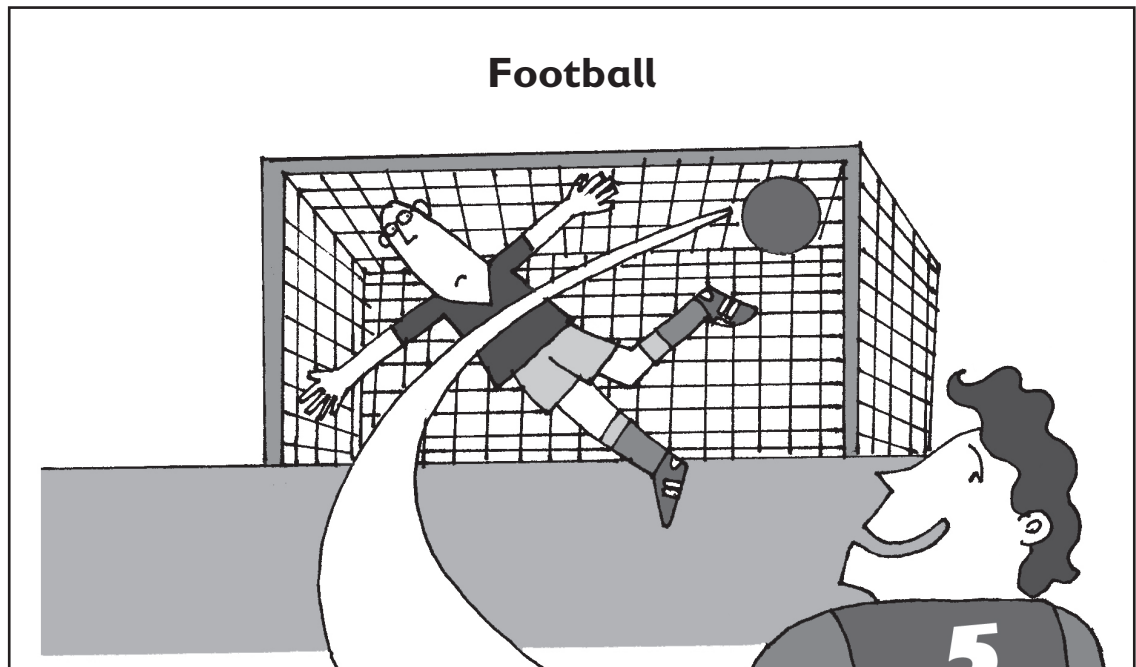

Example You play football on a field with a big white

- 1 ball called a football. There two teams with
- 2 eleven players. Both teams try to score goals
- 3 kicking or heading the ball into the other team's goal.
- 4 Players can use feet, head, legs and chest to touch
- 5 the ball but only the goalkeeper can use his or her hands
- and arms. The winning team is the team with more goals
- 90 minutes. People play football all over the world
- and the football World Cup was in Uruguay
- in 1930.

Example	on	in	at
1	are	is	were
2	from	by	to
3	his	your	their
4	after	before	into
5	first	last	next



Find the Differences



Picture Story



Odd-One-Out